

Sp Series Spa Bath Pumps

Opus® “SP” Series Spa Bath Pump is produced to accommodate spa baths. SP Pump is electricity saved and ultra quiet operation. It's streamlined and compact design with concealed motor shaft constraint makes SP Pump easy to install even in the situation, especially the tightest space with high humidity. Full range of models and accessories are available.

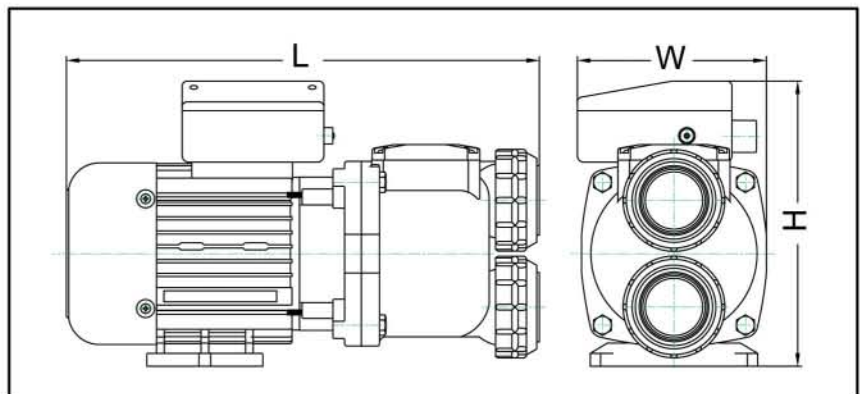

- Streamlined compact design - attractive and simple to install.
- Choice of models for all kinds of bath sizes.
- Accessories available.
- Easily install unions.
- Quiet, safe and reliable operation.

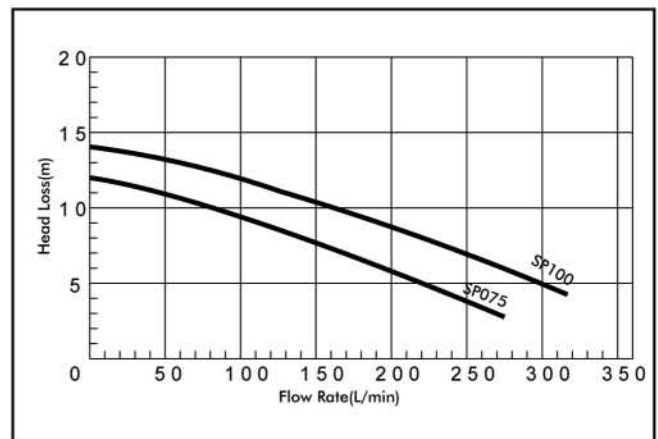

TECHNICAL CHARACTERISTICS

Model No.	Output Power (kW)	Length (mm)	Width (mm)	Heigh (mm)	Weight (kg)	Port Size	Voltage (v)	Phase
SP075	0.55	375	150	220	8.5	1½" / 40mm	220	单相
SP100	0.75	375	150	220	9.1	1½" / 40mm	220	单相